



Trade Science Inc.

ISSN : 0974 - 7443

Volume 6 Issue 4

CHEMICAL TECHNOLOGY

An Indian Journal

Full Paper

CTAIJ 6(4) 2011 [182-189]

Design of a crop residue burner for cereal drying

P.Chemweno*, W.O.Ogola², P.M.Wambua¹, J.Githaiga¹, S.A.Odhiambo¹, N.Kiplagat¹, P.Nziu¹

¹School of Engineering, Moi University, P.O.Box 3900, Eldoret, (KENYA)

²Kenya Polytechnic University College, (KENYA)

E-mail : peterchemweno@yahoo.com; peterchemweno@gmail.com

Received: 9th November, 2011 ; Accepted: 7th December, 2011

ABSTRACT

Annually, farmers in Kenya, farmers incur heavy losses on their harvested cereal crops as a result of employing unorthodox cereal drying methods that include drying on tarmac roads and other unused open spaces in urban areas. This in most cases compromise on grain quality due to in-house grain moulding. Few drying facilities are available but apply stringent quality standards on purchases of grain, and on the other hand cannot effectively handle all the cereals harvested due to their limited capacity. This research seeks to design and develop a crop residue burner to produce heated air for utilization in a direct-fired batch-in-bin dryer. The burner utilizes crop residue left underutilized in the field after each harvest season as fuel. The design concept entails developing a two-section chamber burner with primary and secondary sections. Mild steel plates of 3mm and 5 mm sections are used in the fabrication. Thermal stress computations are used to determine choice of fastening method, with the eventual choice being a combination of arc welding, riveting and fastening. To achieve optimal combustion efficiency, computation of both stoichiometric and actual combustion of exhaust gases is conducted. To achieve complete combustion of the fuel, computational fluid dynamics technique (CFD) is applied and a cyclonic secondary combustion chamber is incorporated to the burner. Fouriers heat transfer equations are applied in the determination of suitable refractory materials in which clay and alumina-silica cement are selected as the optimal choice. It was found that the burner design achieves thermal efficiencies of 57.7%, produces smokeless heated air for use in a batch-in-bin dryer capable of drying approximately 17.82 tonnes of cereals per day.

© 2011 Trade Science Inc. - INDIA

KEYWORDS

Cyclonic chamber;
Thermal efficiency;
Thermal stress;
Refractory lining;
Computational fluid dynamics.

INTRODUCTION

Agriculture is the backbone of Kenya's economy contributing to over 70% of the gross domestic product. In addition to providing livelihood to millions of Kenyans, it provides the much needed food for consumption and thus survival^[1,2].

Despite agriculture being such a vital sector in Kenya, food security remains far from being achieved with millions of Kenyans going without food due to storage shortages experienced in the nation's granary; the National Cereals and Produce Board of Kenya (NCPB).

Maize is Kenya's main staple food and accounts

for 80% of total cereals production with an average per capita consumption of 0.97 tonnes. In 2007, the total estimated maize output was 2.29 million metric tonnes, consisting of long rain production of 1.84 million tonnes. Despite the high maize output, wastage of maize due to improper preservation techniques accounted for a loss of approximately 18.5% of the total gross output^[2].

Grain drying facilities available country wide are solely owned by the NCPB and private millers, with a total of 23 drying facilities spread across the country. Despite the limited availability of these facilities, NCPB applies stringent quality measures when purchasing cereal grains from farmers. Farmers are required to supply maize with a maximum moisture content of 13% and rotten grain at maximum of 1%. Due to these stringent quality standards applied, farmers often resort to two options of either:

- I. Delivering maize to middlemen at throw away prices, or
- II. Drying their cereals on tarmac roads and other open spaces oblivious of associated hygienic dangers

Furthermore, improper storage of maize after harvest with moisture content of more than 18% leads to increased in-house mould development associated with aflatoxin poisoning (mould growth on the cereal kernel). In the past, aflatoxin poisoning has led to human fatalities especially in the eastern region of Kenya^[3].

Usually, oil and gas are the conventional fuels employed in heated air dryers, particularly so for small scale operations such as batch-in-bin dryers. The use of these fossil fuels is increasingly becoming expensive and environmentally undesirable. The use of alternative renewable energy sources has gained a lot of research attention going by the new combustion technologies currently under development. In many areas the residues available from grain crops such as maize cobs, wheat straw, and rice husks are available in large quantities, but are generally under-utilized and present disposal problems. Depending on the crop production systems applied, other agricultural residues may be produced in the vicinity of grain drying plants and may offer alternative fuel options.

Few comprehensive studies have been made of biomass residue availability. However, estimates have been established from the ratio of crop yield to residue, data for which is shown in TABLE 1. The estimated country-wide production of agro-residues (calculated from the crop to residue ratio) is given in TABLE 2. Much of this material has potential use in a wide range of applications, but in many cases is underutilized. TABLE 3 provides details of calorific values of selected agro-residues and wood^[5].

There are many different combustion systems that are current and potentially suitable for combustion of biomass residues. The broad classification of types and their status of development are outlined below:

TABLE 1 : Conversion Ratios for the Estimation of Crop Residues^[3]

Crop	Residue	Crop: Residue Ratio
Barley	Straw	1:1.2
Maize	Straw	1:2
Millet	Straw	1:1.4
Oats	Straw	1:1.3
Sorghum	Straw	1:1.4
Soya beans	Straw	1:1.1
Wheat	Straw	1:1.3

TABLE 2 : Estimation of Crop Residue Production in Kenya for the year 2009^[4]

Crop	Production million tonnes	Residue	Production million tonnes
Barley	0.44	Straw	0.56
Maize	2.29	Straw	4.58
Millet	0.53	Straw	0.61
Sorghum	0.14	Straw	0.18
Wheat	1.55	Straw	1.76

TABLE 3 : Heat energy content of crop residue^[5]

Material	Gross Calorific Value MJ/Kg
Maize stalks	18.2
Maize cobs	18.9
Rice straw	15.2
Rice husks	15.5
Soybean stalks	19.4
Wheat straw	19.0
*Industrial Diesel Oil	37.0
*Propane	46.57
*Coal (lignite)	20.0

Full Paper

Grate furnace

Grate furnace is probably the most commonly used combustion system. There exist grate systems for burning a wide variety of biomass materials, including many particulate residues and straw. The grate is designed to support the biomass fuel and allow air to circulate freely through it. This system exhibits thermal efficiency of between 55-59%. It operates at a maximum temperature of 1000°C and is often used to burn rice husks^[6].

However several shortcomings have been noted by Kumar and Fleckl when the system is used for combusting crop residues as fuel. These include uneven fuel distribution, difficulty in controlling air-to-fuel ratios, and high percentage of unburnt residue in ash^[4,5].

Fluidized Bed Systems (FBD)

These systems are especially suited for burning both large and small particulate agricultural residues of relatively high moisture contents. The fluidized bed furnace comprises a combustion chamber containing a sand bed acting as the heat transfer medium. They exhibit moderate thermal efficiency of between 45-55% with a temperature range of between 750°C and 950 °C. Their main advantage is their capability of operating below the temperature range for production of noxious gases i.e. NO_x. Although ideal in combusting crop residue, FBD systems require high capital expenditure, skilled expertise in their operation and high energy needs to power fans necessary for achieving complete fuel combustion^[4,5,7].

This paper discusses the design process for a burner that utilizes crop residue biomass as its primary source of fuel.

MATERIALS AND METHODS

Materials and design procedure

In the design of the burner, cereal straw is the main source of fuel to be used, while for construction of the burner, mild steel and refractory lining of fire clay and alumina sulphate cement were used. For the burner design, a criterion was used in determination of the optimal design to be selected. The criteria considered the following; safety, reliability, eases of operation, environmental friendliness, and cost of operation and main-

tenance. Several burner designs were developed with each design being evaluated based on a 1-9 score assignment for each design. The design with the highest score was eventually adopted as shown in Figure 1 (1:10 engineering scale drawing of the crop residue burner).

Primary chamber sizing is based on the fuel density, and shape considerations. A rectangular section was thus determined to be most appropriate considering ease of manufacture, fuel combustion and ease of operation. Modeling for the secondary cyclonic shape was carried by use of Computational Fluid Dynamics (CFD). Selection of appropriate refractory material is based on principles of Fourier law (heat transfer by conduction) and Mac Adams equation (heat transfer by natural convection)^[8,9].

Sizing of primary combustion chamber

The primary chamber is of rectangular section. It has clay refractory lining on its inside wall with alumina silica cement and the bonding agent. On top of the primary chamber is an airtight fuel feed door. Airtight conditions for the fuel feed door is achieved through providing a water-tight seal on the door channel. The rectangular section facilitates ease of construction, including laying down brick work and lessens maintenance. Above the base of the primary chamber, a grate constructed from Y12 twisted mild steel rods is fitted to prevent fuel from falling to the base, while at the same time allow easy collection of ash. The working model drawn to a scale of 1:10 is represented in Figure 2. The dimensions of the primary chamber are 2 meters height by 1.24 meters width by 1.24 meters length. The size is determined by considering the amount of fuel required to produce a constant volume flow rate of heated air fed to the dryer to dry the batch weight.

The volumetric capacity of the burner is another important determinant of the amount of energy required to raise the ambient air temperature to an optimal level for drying cereals. It is computed by knowledge of data on the volumetric flow rate of hot gaseous products of combustion, and the temperature difference required in the heated air. After the burner capacity was determined, the dryer size was computed from the principles of moisture shrink (amount of water lost as the cereal grain dries to standard moisture content of 14%). Through comparing the water evaporated from the grain, as a

percentage of the total grain weight, the dryer capacity was determined.

The inner walls of the primary chamber have a lining of fire clay refractory brick. Choice of the lining material and thickness is determined by considering heat transfer through the burner wall. The chamber wall is a composite since it has more than one layer. Fourier heat transfer equation used is given by equation 1:

$$Q = \frac{A(t_1 - t_2)}{\frac{x_1}{K_1} + \frac{x_2}{K_2} + \frac{x_3}{K_3} + \dots + \frac{x_n}{K_n}} \quad (1)$$

Where Q is the heat transfer through burner wall in Joules/second; A is the heat transfer area; t_1 and t_2 is the inlet and outlet phase temperature on the burner wall respectively; x_n the material thickness; and K_n the coefficient of thermal conductivity of individual refractory lining layer^[8,9].

Cyclonic secondary chamber design and sizing

The secondary combustion chamber is constructed in a cyclonic shape and incorporated to the primary chamber so as to achieve complete fuel combustion. Choice of the combustion shape was determined based on the Computational Fluid Dynamics (CFD) simulation software. Through CFD, evaluation of hot air velocity, pressure, temperature, and concentration was made considering different burner shapes and sizes. The model set-up for the CFD experimentation is based on the work of Fleckl et.al and involves constructing a computational mesh utilizing body-fitted coordinate's approach, which allows the creation of the grid of complex geometry^[5,11]. From the simulation, the cyclonic shape is determined to give the best possible results.

On the chamber surface, refractory lagging of fire brick is laid with alumina silica cement applied as the bonding agent. Thickness of the lagging layer is determined through Fourier's law of conduction given by equation 2:

$$Q = \frac{2\pi L(t_1 - t_2)}{\ln\left(\frac{r_2}{r_1}\right) + \dots + \ln\left(\frac{r_n}{r_{n-1}}\right)} \quad (2)$$

Where Q is the heat transfer through the secondary chamber wall; r_1 and r_2 outside and inside radius of the cyclonic chamber; and L the chamber length^[8,9].

Choice of construction material

The criteria for choice of material is based on the following: strength at room temperature; material toughness; material cost; local availability; material density; ease of manufacture resistance to surface and granular corrosion. A score sheet of 1-9 is used for comparing possible construction materials based on the discussed criteria. From the selection process, mild steel is selected for the construction of the burner body. It has a tensile strength of 380 MN/m², density of 7800kg/m³, Young's Modulus (E) of 200GN/m², and a coefficient of expansion (α) of 12×10^{-6} ^[11].

Fire-brick clay refractory is selected because of its excellent refractory properties (thermal conductivity of 0.9375 W/mK, melting point of 2800°C, and coefficient of expansion of 6×10^{-6} metre per °C. Similarly high alumina cement (composite of limestone and bauxite) has excellent refractory properties with a thermal conductivity of 32 W/mK, melting point of 2500°C, coefficient of expansion of 6×10^{-6} metre per °C^[8,9].

The structural strength of hinges required to support the burner doors was determined through considerations of total door weight. Forces acting on the door were assumed to act as a cantilever. From theory of bending moments and shearing forces, the bending stresses and deflection were thus computed. Based on the deflection of the burner door, the total bending stress was determined and thus the number of hinges supporting the burner door. Determination of maximum linear deflection is based on equations (3) and (4).

$$EI = \frac{d^2y}{dx^2} = -M \quad (3)$$

Where E is young's modulus of elasticity, M is bending moment and I is the 2nd moment of area.

$$y_{\max} = \frac{wL^4}{8EI} \quad (4)$$

Where y_{\max} is the maximum deflection, w the distributed load in Newton metre, I the 2nd moment of area and L the total length of the door^[12].

Full Paper

Exhaust flue gas analysis

The ultimate analysis of the fuel considered in which the elemental composition of the fuel in terms of carbon, oxygen, sulphur, water vapour, nitrogen and ash contained as percentage of the total mass of the fuel. By use of combustion equations, both the stoichiometric and actual Air: Fuel ratios were determined and using this data, the total volumetric quantity of heated products of combustion was then computed. As a result, the quantity of heated air produced proved useful in computing the burner capacity and sizing the grain dryer.

Calculating temperature stress and weld efficiency for welded chamber joints

High temperature induces temperature stresses on the burner chamber walls. The chamber composite walls (mild steel body and refractory lining) are affected by the interfacial temperature and thus result in induced stress. The temperature stress is calculated from equation (3) described by Stephens:

$$\frac{\sigma_{\text{steel}}}{E_{\text{steel}}} + \frac{\sigma_{\text{refractory}}}{E_{\text{refractory}}} = (a_{\text{refractory}} \times \text{temperature change in refractory} - a_{\text{steel}} \times \text{temperature change in steel}) \quad (5)$$

Weld efficiency is calculated by considering principles of tensile strength analysis of riveted and welded joints. A welded wall specimen is considered with tensile force applied on opposing directions till breakage occurs. The maximum tensile force is measured and tensile stress computed through simple direct stress equations given by equation (4)^[12]:

$$\text{Direct stress on welded joint } (\sigma) = \frac{\text{Tensile force action (F)}}{\text{Wall cross-sectional area (A)}} \quad (6)$$

Cost comparison between residue fuel and industrial diesel oil (IDO)

IDO is the most popular fossil fuel used for cereal drying. This is due to its adaptability for small burner design, ease of storage and transportation. As such, it was found necessary to make an economic cost comparison between use of IDO and crop residue as fuel. The cost of IDP for the designed burner capacity and that for the crop residue for the same capacity was thus

compared taking into account factors such as unit transportation cost and labour requirements (loading of residue fuel to burner, manual transportation and manual fire stoking).

RESULTS AND DISCUSSION

The wet gravimetric analysis of the products of combustion from the residue fuel is shown in TABLE 4 for a combustion efficiency of 95% which is desirable for any ideal combustion system.

TABLE 4 : Stoichiometric and actual flue gas analysis

Product	Mass (kgs)	% Mass	M (mol)	$n = \frac{m}{M}$	% Vol, Wet
CO ₂	1.86	18.46	44	0.0423	12.26
H ₂ O	0.553	5.49	18	0.0307	8.901
SO ₂	0.00004	0.000397	64	6.25×10^{-7}	0.000181
O ₂	0.3685	3.658	32	0.0115	3.334
N ₂	7.292	72.38	28	0.2604	75.5
Total	10.0735		186	0.34493	95%

The total quantity of hot gases given out for complete combustion was determined to be 2792m³ of hot air per fuel feed (80 kg per of crop residue cereal straw per feed). This result reflects that in order to achieve complete combustion of the residue fuel, the products of incomplete combustion from the primary chamber such as carbon monoxide and Nitrogen oxide should further be burnt in the presence of secondary air (this explains the importance of incorporating the cyclonic secondary chamber).

The design thermal efficiency of the burner was determined to be 55.7%. For this efficiency, the thickness of the refractory lining was determined as being 0.093 metres for the primary chamber and 0.105 metres for the secondary chamber. These results compare favorably well with modern crop residue combusting systems such as the fluidized bed system and the grate furnace whose thermal efficiencies range between 45-59%^[5].

For the secondary combustion chamber, a cyclonic shape is incorporated as shown in Figure 3, and gives the following results:-

- Impacts a swirling action i.e. circular motion in conjunction with the tangentially arranged secondary air nozzles. The combination of the cyclonic shape and

tangentially arranged secondary air injection nozzles leads to a high turbulent mixing, homogenous flue gas distribution and a good utilization of the secondary combustion zone. Furthermore, the swirling action eliminates smoke and filters out fly-ash passed on to the secondary chamber from primary chamber.

- The cyclonic shape concentrates heat at the centre of the chamber and this assists completion of the combustion process. Moreover, this has an effect of raising the temperature of the hot gases fed into the burner to approximately 1000°C. The results of the cyclonic chamber design (temperature rise), agrees with experiments conducted by^[6] whereby CFD simulation is used to determine optimal burner shape designs.

The burner capacity from the volumetric flow rate of the hot gases was 59.2 m³ per hour and when incorporated to a batch-in-bin dryer, is capable of drying 0.735 tonnes of cereal per hour and over a 12 hour period, capable of drying 8.82 tonnes of cereals. These results indicate the high potential for use of crop residue as an alternative source of fuel and the high quantity of grain that can be dried will enable many small scale farmers dry their cereals.

The doors of the primary chambers require 3 hinges for support with a total safety factor of 4 which as determined by^[7] is within the allowable limits of safety. Furthermore, the maximum bending moment is depicted in Figure 2 as 5.98 KN/m per hinge, from which the maximum bending moment is 268.2 KN/m².

GRAPH OF LENGTH (X) AGAINST BENDING MOMENT FOR BURNER FUEL DOOR

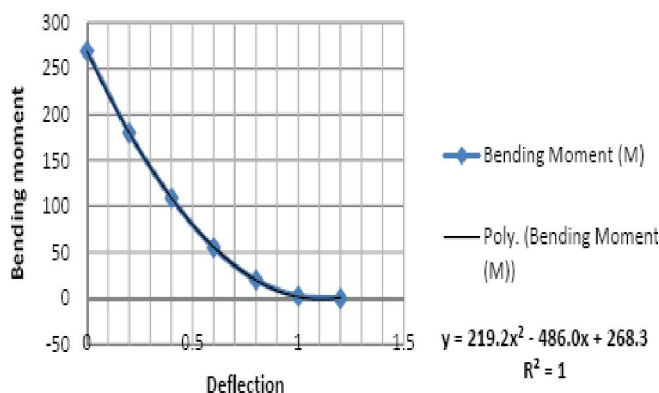

Figure 1 : Graphical Representation of Maximum Bending Moment against Deflection for the Burner Feed Door

The economic feasibility is done through cost comparison between use of residue fuel and industrial diesel oil for the same burner design capacity is illustrated by the graphical relationship below:

COST COMPARISON BETWEEN RESIDUE FUEL AND INDUSTRIAL DIESEL OIL

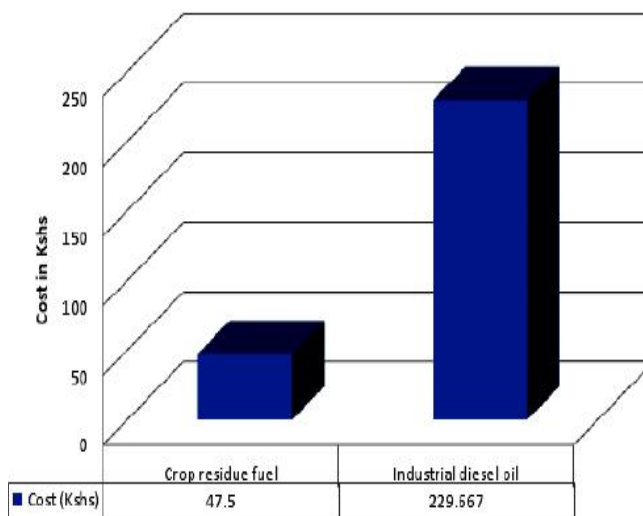

Figure 2 : Economic Feasibility of Utilizing Crop Residue as Fuel for Cereal Drying

By comparison residue fuel use costs of approximately Kshs 47.5 per burner capacity while the cost of I.D.O for the same capacity is Kshs 230. This shows that the cost saving that can be achieved by use of residue fuel is reasonably high.

CONCLUSIONS

In this paper, a burner is designed and developed using locally available resources, its optimized in design and material selection. The potential of use of crop residue as a fuel substitute in grain drying facilities in comparison with fossil fuels such as IDO is evaluated. Results show that by appropriate design of a residue burner, a thermal efficiency of 65.5% is achieved with complete combustion of the fuel. Furthermore, cost comparison of using crop residue fuel compared to industrial diesel oil shows that the residue fuel reduces operation cost associated with fuel by more than 50%. The design is best suited for drying cereals in rural areas in developing countries due to its simplicity and functionality. It uses natural draught and eliminates need for motors necessary in forced draught operation. Furthermore, its construction is from locally available material.

Full Paper

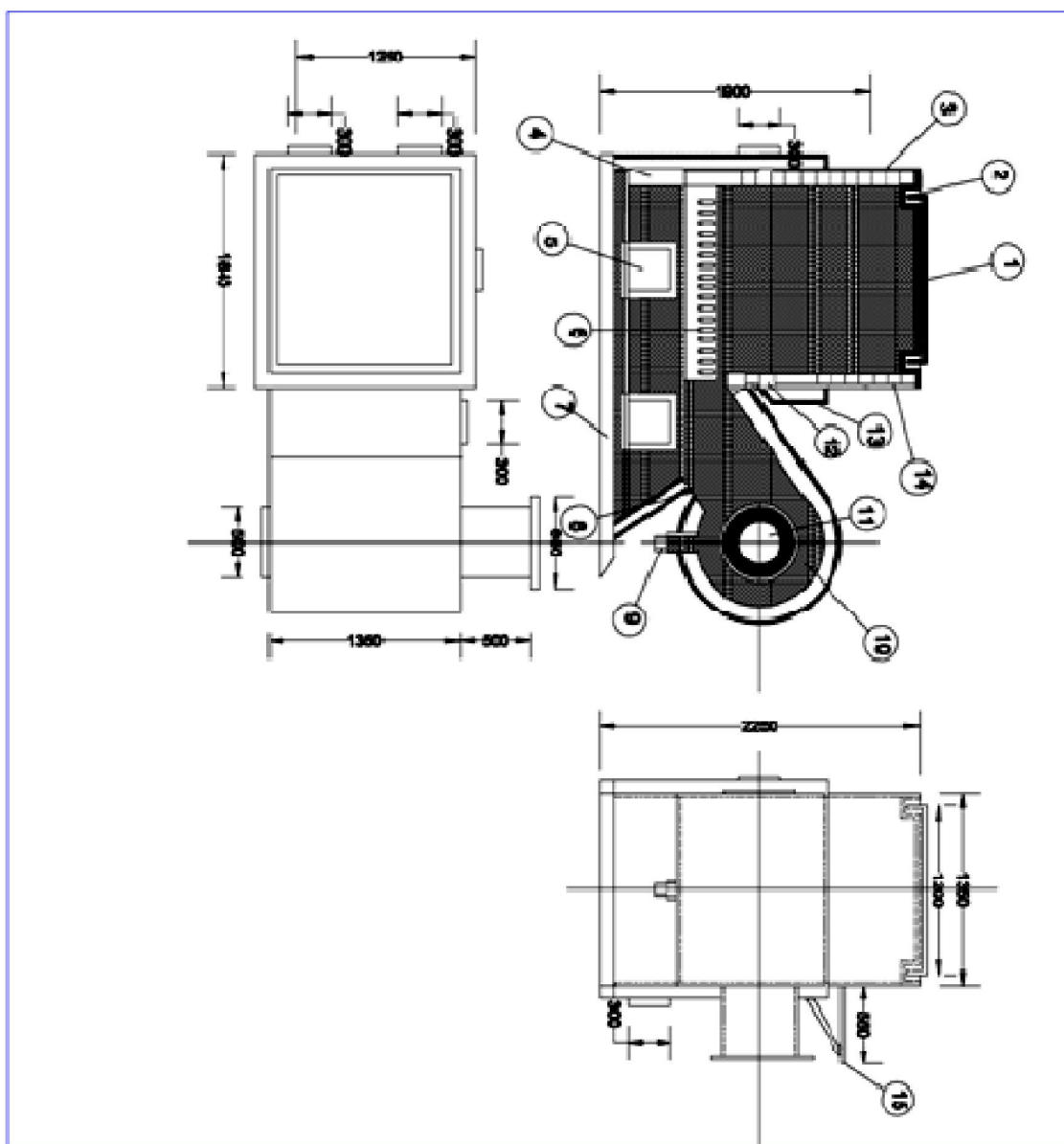

PART NO	DESCRIPTION	NO OFF
16	LOADING PLATFORM	1
14	FIRE CLAY BRICK REFRACTORY	1
13	STEEL AIR JACKET	1
12	AIR INLET NOZZLE	8
11	HOT AIR OUTLET DUCT	1
10	SECONDARY CHAMBER	1
09	SECONDARY ASH OUTLET	1
08	SECONDARY AIR INLET	1
07	CHANNEL IRON BASE	4
06	IRON GATE	1
05	PRIMARY ASH DOOR	2
04	AIR INLET DOOR	2
03	MILD STEEL SHELL	-
02	WATER BEAL	-
01	FUEL FEED DOOR	1

INSTITUTION NAME: IJCI UNIVERSITY
 ADDRESS: P. O. BOX 9900-30100
 ELDORET

TITLE:
 DESIGN OF A CROP RESIDUE FUEL
 BURNER

PROJECT: JOURNAL PAPER
DATE: 30/08/2011
SCALE: 1:10

Figure 3 : A 1:10 scale Engineering Drawing Representation for the Burner Design

It can thus be concluded that crop residue has a great potential for use in grain drying facilities and can complement fossil fuel currently in use with the overall effect of reducing operation costs of dryer installations. This is in addition to availing grain drying facilities to farmer's cooperative societies (due to its size), thus improving grain quality, quantity, therefore increases the ultimate revenue achieved by the farmers. This contributes to possible sustained food security.

REFERENCES

- [1] United States Agency for International Development (USAID) - Famine Early Warning Systems Network, Kenya "Widening Maize Supply Deficit to Accentuate Food Insecurity, Kenya Food Security Alert" FEWSNET, Kenya Food Security Alert Report, December, (2009).
- [2] B.Owour; "The Maize Subsector In Kenya: Mending The Granary." Survey For Heinrich Boll Foundation Regional Office For East & Horn Of Africa Nairobi, Kenya, May, (2010).
- [3] R.Yevich, J.Logan; Global Biogeochemical Cycles, 17, 55-70 (2003).
- [4] A.Kumar, "Biomass as Fuel in Small Boilers" Asian Productivity Organisation, (2009).
- [5] T.Fleckl, J.Helmunt; "Combustion Diagnostics at A Biomass-Fired Grate Furnace Using FT-IR Absorption Spectroscopy for Hot Gas Measurements." Proceedings of the 5th European Conference On Industrial Furnaces And Boilers, Rio Tinto, Portugal, (2000).
- [6] J.Koppejan, S Loo; "Modelling and Process Control of Grate Furnaces." Workshop on Optimization and Design of Biomass Combustion Systems, Vienna Austria, (2005).
- [7] R.Risto; "Fluidised Bed Combustion Boilers" International Sustainable Energy Review, December, (2009).
- [8] T.D.Eastop, A.Mcconkey; "Applied Thermodynamics for Technologists" Longman Publishers, 5th Edition (2004).
- [9] F.C.Rogers, R.Y.Mayhew; "Thermodynamic and Transport Properties of Fluids" Blackwell Oxford UK & Cambridge USA, (1995).
- [10] R.Scharler, I.Obernberger; "Numerical Modeling of Grate Furnaces" Proceedings of the 5th European Conference on Industrial Furnaces and Boilers, Porto, Portugal, (2000).
- [11] F.Bower; "Applied Mechanics of Solids" CRC Press Taylor and Francis Group Publishers, (2010).
- [12] R.C.Stephens; "Strength of Materials, S.I.Units Theory and Examples" Longman Publishers, (1970).